

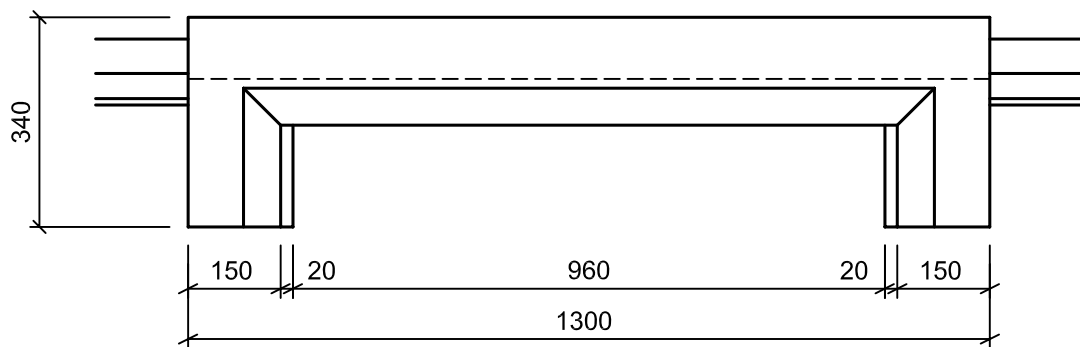

PRODUCT DRAWING

SVC PRODUCTS PTY LTD
38 Japaddy St, Braeside, Vic, 3195
Ph: 9580 6644 Fax: 9587 2805
sales@svc.net.au
www.svc.net.au
ABN 96 004 279 458

SVC PRODUCT CODE	15.305
PRODUCT DESCRIPTION	1300 K/LINTEL RCA B W/LEGS



ELEVATION

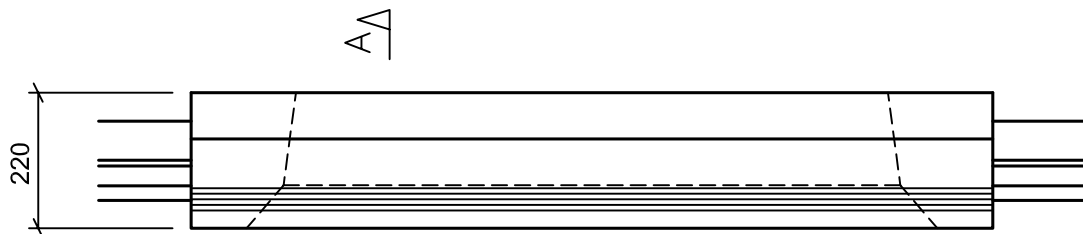

PLAN

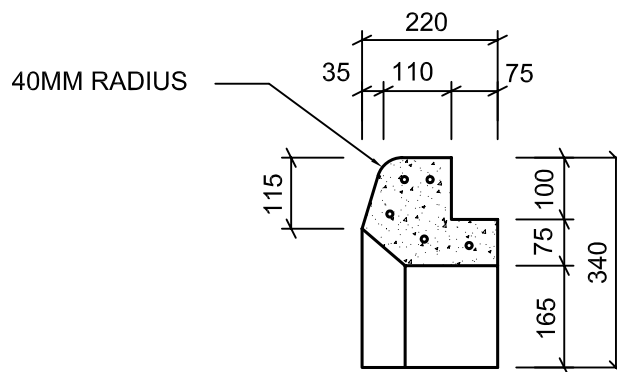

SECTION A-A